

1. Begin with the color desired for the wings facing up. Fold in half, edge to edge. Unfold.

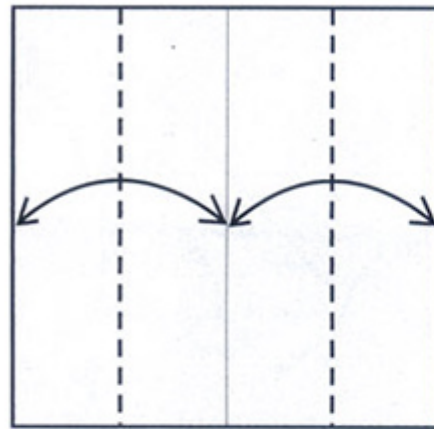

2. Fold left and right edges to the crease.



3. Fold in half, short edges together.

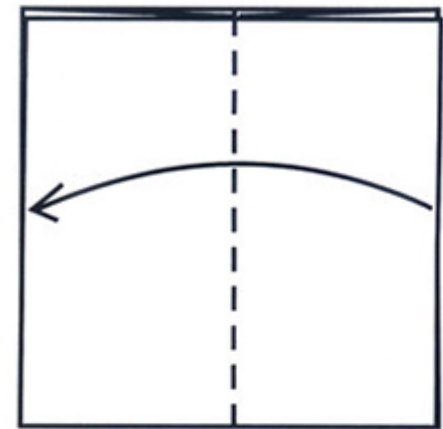

4. Fold in half, right-side double folded edges to the left.

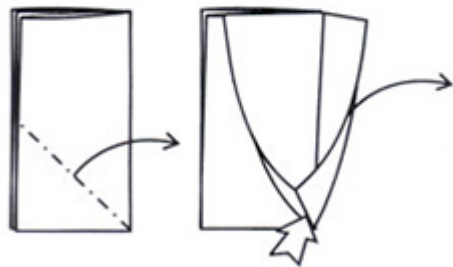

5. Squash-fold the bottom corner.

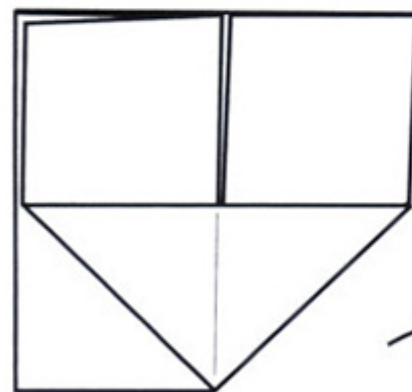

6. Your paper should look like this. Turn over.

7. Squash-fold the bottom corner.

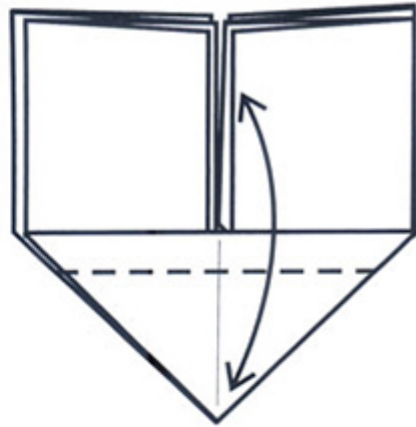

8. Fold up the bottom corner, about one quarter down from the middle folded edge.
Unfold.

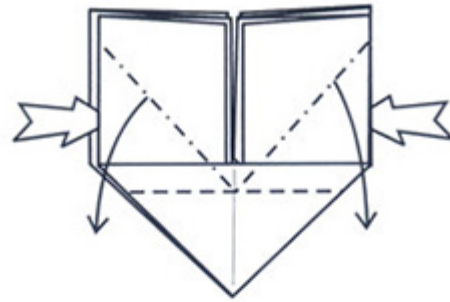

9. Squash-fold the upper left and right sections, being careful to make the squash creases hit the center of folded line made in the previous step.

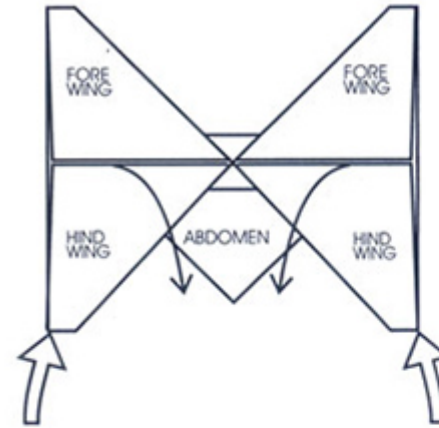

10. Your paper will look like this. With the abdominal corner at the bottom, move the top layers of the hind wings down, squashing the bottom corners of both wings.

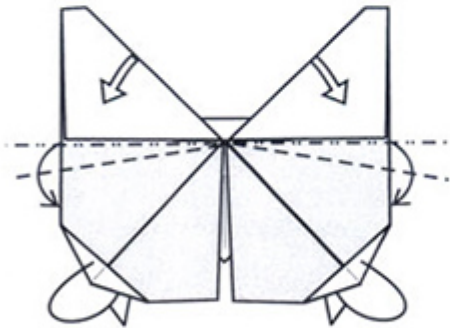

11. Form a mountain crease edge across the middle of a wing and move it downward, reshaping the forewing and defining a separation between the forewings and hind wings. Repeat with the other wing. If desired, turn the triangle of paper on each hind wing inside out.

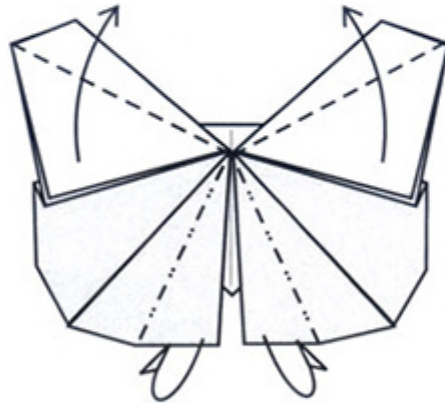

12. Mountain-fold the hind wing edges under to reveal the abdomen. Fold up the top layer of the forewings.

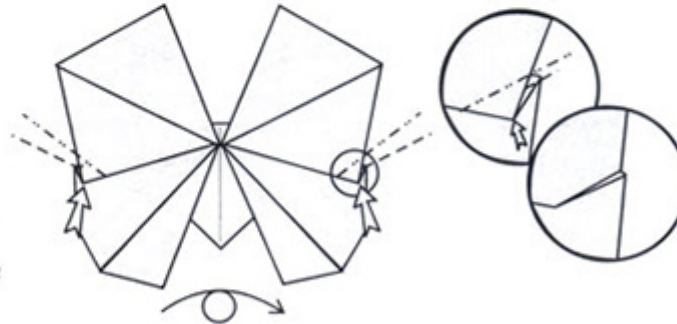

13. Inside-reverse-fold the indicated corners at the separation point of the forewings and hind wings. Turn over.

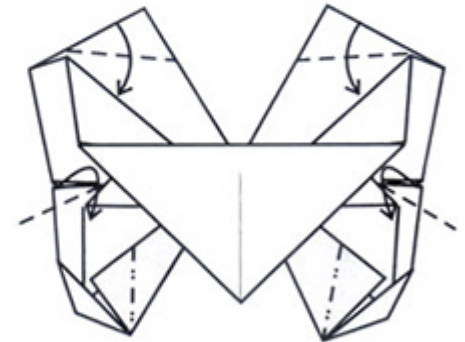

14. Clean up the back side with the indicated folds. You can be creative with the shapes of the top folds and the midside folds.

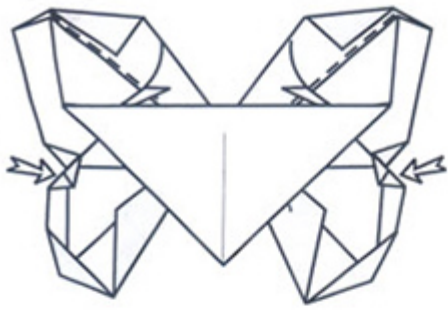

15. Fold the top edges inside. Notice the notches created at the midside points.

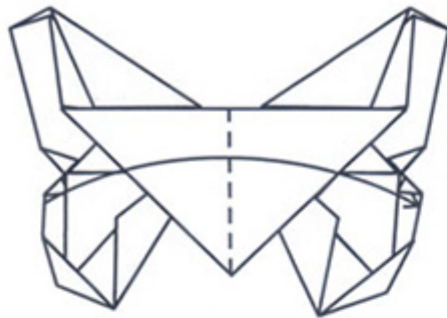

16. Fold in half.

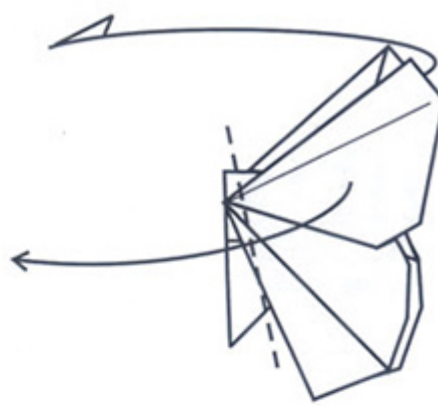

17. Fold each wing set against the body, one to the left and one to the right. You can be creative with the angle.

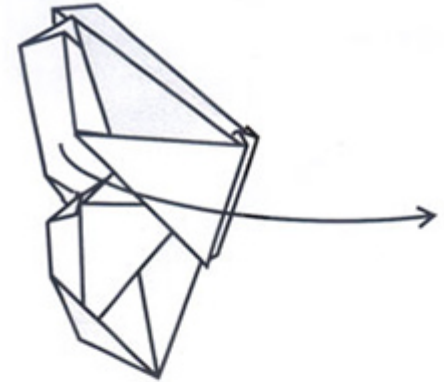

18. Open, display side up.

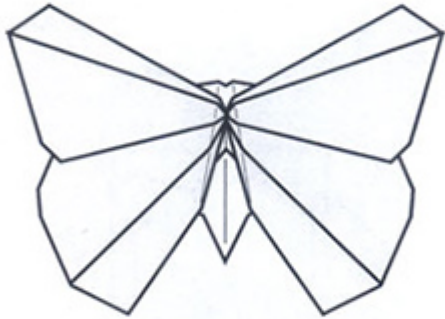

19. Your model should now look like this.

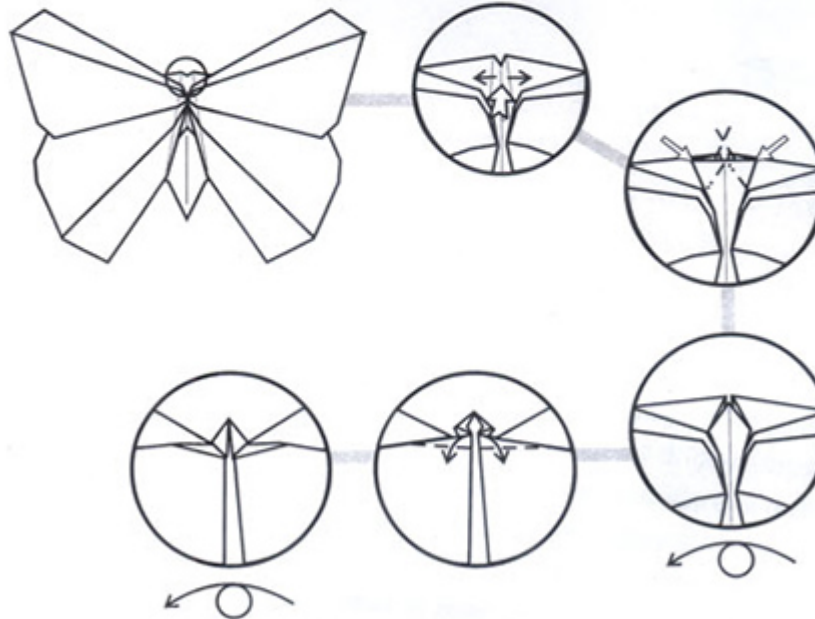

20. Head detail. Squash-fold the center rib in the head area.

21. Inside-reverse-fold the top corners, left and right.

22. Turn over.

23. Fold edges down.

24. Turn over.

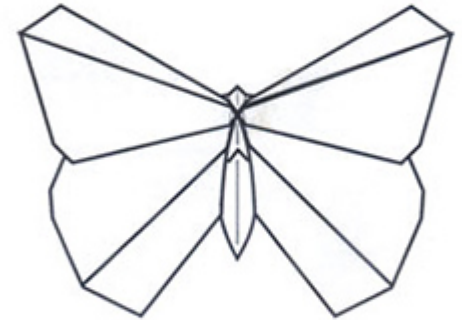

25. The finished Origamido Butterfly.

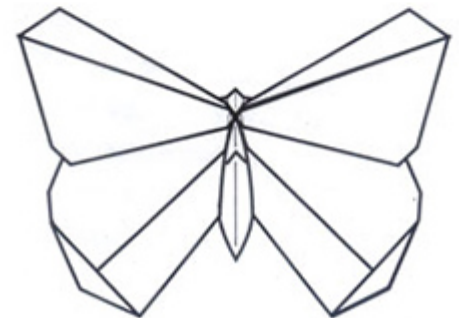

26. This version leaves the triangle layer displayed upon the hind wings.